

ABS submersible drainage pump J 405

Specification

Electric submersible pump.
 Maximum submergence: 20 m. • Protection class IP 68.
 Max temperature of pumped medium at max power input and continuous duty 40°C.
 Max medium density 1100 kg/m³. • pH of the pumped medium 5-8.
 Strainer hole 8 x 34 mm. • Max number of starts 30/hour.

J 405 ND Medium head, 3-phase.

J 405 HD High head, 3-phase.

Electric Motor

3-phase squirrel-cage induction motor, 50 Hz.
 Service factor 1.1. Class F insulation.

Motor rating P₂: 35.0 kW. Speed: 2930 rpm

Voltage, V	230	400	500	1000
Nominal current, A	108	62	50	25

Starting method

D.O.L. start with built-in contactor (230-500V).
 D.O.L. start with built-in terminal block (230-1000V).
 Star-Delta start with built-in terminal block.
 When used with VFD, pump must be equipped with terminal block instead of contactor.

Power Cable

20 m type S1BN8-F (standard cable):

4x16 sq.mm. (400-500V DOL-start with contactor)
 4x16 sq.mm. + 4x1.5 sq.mm. (400-500V DOL-start with terminal block)
 2-4x25 sq.mm. + 4x1.5 sq.mm. (230V star-delta start)
 2-4x10 sq.mm. + 4x1.5 sq.mm. (400-500V star-delta start)

20 m type NSSHÖU.../3E (heavy duty cable):
 3x6+3x6/3E+3x1.5 (3 control cables included) (1000V D.O.L.-start)
 3x16+3x16/3E+3x2.5 (3 control cables incl.) (400-500V D.O.L.-start)

Motor Protection

Built-in thermal switches in the stator windings (140°C, ±5), connected to built-in contactor or to separate control box. DI leakage sensor as option, but not in combination with built-in contactor.

Shaft Seal

Double mechanical seal in oil bath, mounted in seal cartridge for easy service.
 Primary seal: Silicon carbide on silicon carbide.
 Secondary seal: Silicon carbide on antimony treated carbon.

Bearings

Upper bearing: Single-row deep groove ball bearing.
 Lower bearing: Double angular contact ball bearing.

Materials		EN	ASTM
Casing and castings	Aluminium	EN 1706: AC-43100	ASTM AlSi10mg
Strainer / Handle / Fasteners	Stainless steel	10088:X5CrNi18-10 (1.4301)	AISI 304
Shaft	Stainless steel	10088:X20Cr13 (1.4021)	AISI 420
Impeller	Hardened chrome steel	10088:X30Cr13 (1.4028)	AISI 420
Wear parts / O-rings	Nitrile rubber		

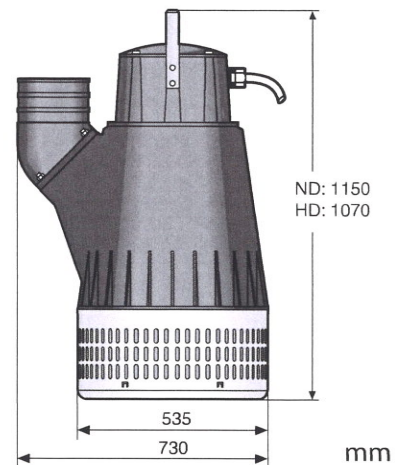
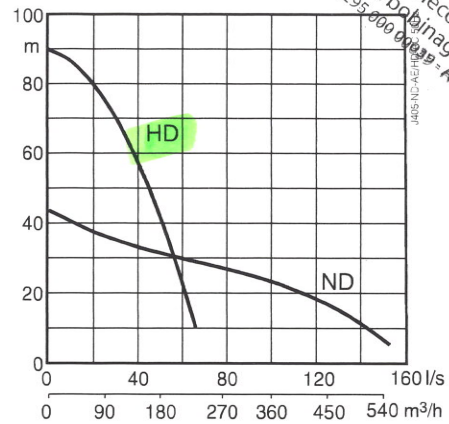

Discharge Connections

4" (HD standard), 6", 8" (ND standard) hose connections.
 4", 6", 8" B.S.P. threaded connections.

Weight (without cable)

270 kg

Options and Accessories

Zinc anodes • Surface protection coating
 Wear plate in polyurethane • Series connection (HD)
 Starter and control units • Automatic level control unit
 Flootation system • Repair kit
 Discharge connection accessories and hose

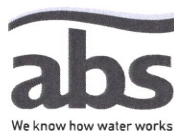

S.A.S. BOBINAGE ARMORICAIN
 Z.I. TRÈS LE BOIS - RUE D'ARSONVAL
 22600 LOUDEAC
 Tél. 02 96 28 01 78 Télécopie 02 96 28 69 93
 Email : contact@bobinagearmoricain.fr
 Siret 311 295 000 0039 - APE 3314Z